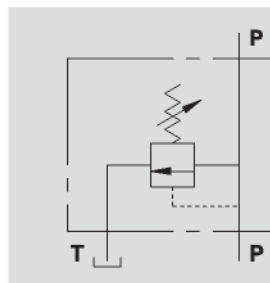

# VALVOLE DI MASSIMA PRESSIONE RELIEF VALVES

TIPO / TYPE

**VMP**SCHEMA IDRAULICO  
HYDRAULIC DIAGRAM**IMPIEGO:**

Valvola utilizzata per limitare la pressione di un circuito idraulico ad un determinato valore di taratura. Al raggiungimento di tale valore la valvola si apre e scarica la pressione in modo che questa non salga oltre il valore di taratura.

**MATERIALI E CARATTERISTICHE:**

Corpo: acciaio zincato.  
Componenti interni: acciaio temprato termicamente e rettificato.  
Guarnizioni: BUNA N standard.  
Tenuta: a cono guidato. Trafilamento trascurabile.

**MONTAGGIO:**

Collegare il ramo del circuito in pressione a P e il ramo di scarico a T. L'attacco P è reversibile.

**A RICHIESTA**

- molle per diversi campi di taratura (vedi tabella)
- pressioni di taratura specifiche (CODICE/T000 specificando il valore di taratura)

PRESSIONE / PORTATA  
PRESSURE / FLOW

**USE AND OPERATION:**

The relief valve limits the maximum pressure in a circuit to the valve's setting. When the circuit pressure reaches the setting, the valve opens and stops the circuit pressure going any higher.

**MATERIALS AND FEATURES:**

Body: zinc-plated steel.  
Internal parts: hardened and ground steel.  
Seals: BUNA N standard.  
Leakage: Guided poppet - negligible leakage.

**CONNECTIONS:**

Connect circuit port with pressure to P and tank port to T. Port P is reversible.

**ON REQUEST**

- different setting range (see the table)
- other setting available (CODE/T000 please specify the desired setting)

Temperatura olio: 50 °C - Viscosità olio: 30 cSt  
Oil temperature: 50 °C - Oil viscosity: 30 cSt

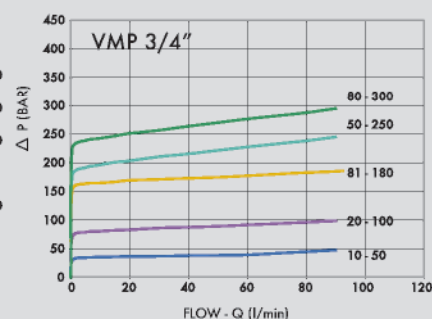
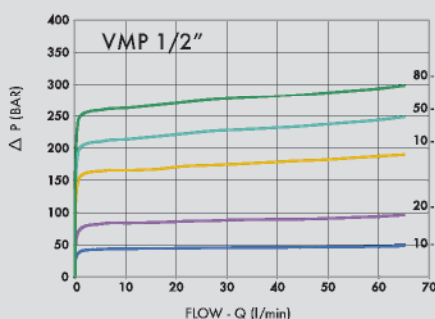
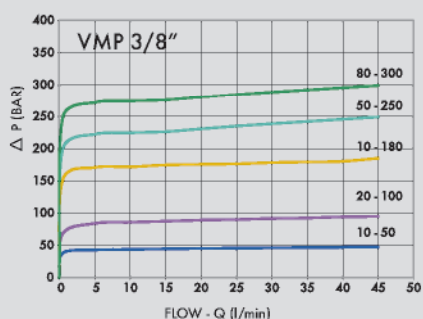



CODICE CODE	SIGLA TYPE	PORTATA MAX MAX FLOW lt. / min	PRESSIONE MAX MAX PRESSURE Bar
<b>V0700/000*</b>	VMP 3/8"	45	350
<b>V0710/000*</b>	VMP 1/2"	70	350
<b>V0720/000*</b>	VMP 3/4"	90	350

\*000 = specificare valore della molla desiderata. Vedi tabella sotto.  
\*000 = please specify the desired setting range. See the table below.

4

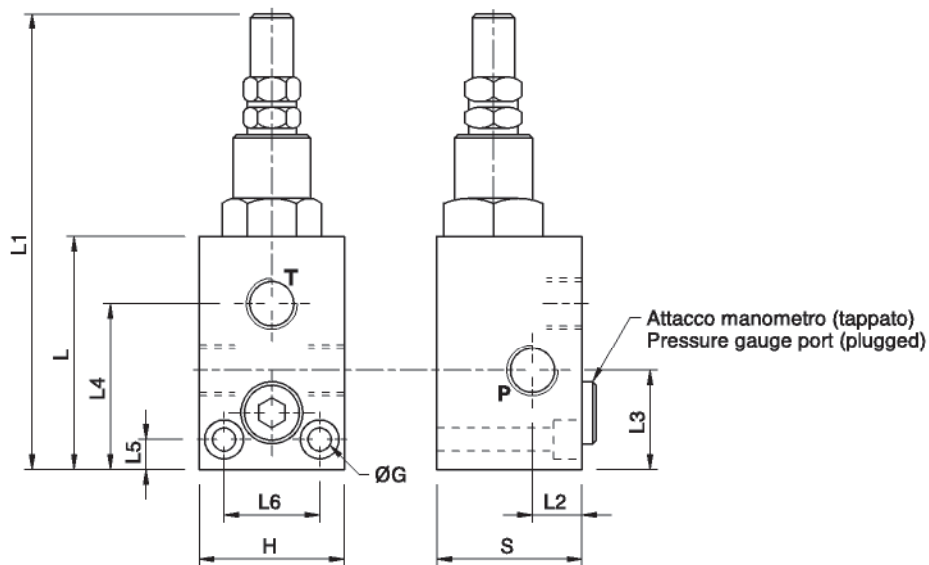

CODICE CODE	SIGLA TYPE	P-T GAS	L mm	L1 mm	L2 mm	L3 mm	L4 mm	L5 mm	L6 mm	G mm	H mm	S mm	PESO WEIGHT kg
<b>V0700/000*</b>	VMP 3/8"	G 3/8"	72	134	15	26	49,5	8,5	26	6,5	40	40	0,824
<b>V0710/000*</b>	VMP 1/2"	G 1/2"	77	139	17,5	29,5	54	8,5	30	6,5	45	45	1,058
<b>V0720/000*</b>	VMP 3/4"	G 3/4"	92	154	20	35	68	10	32	8,5	50	50	1,470

**MOLLE - SPRINGS**

campo di taratura Setting range (bar)	Incremento bar per giro Pressure increase (bar/turn) Q= 4l/min	Taratura standard Standard setting (bar)
10 - 50*	7	30
20 - 100	12	75
10 - 180 standard	30	90
50 - 250	45	130
80 - 300	50	150

**REGOLAZIONE - ADJUSTEMENT**

CODICE/V • CODE/V	Volantino • Handknob
CODICE/PP • CODE/PP	Predisposizione alla piombatura • Arranged for sealing cap
CODICE/P • CODE/P	Piombatura • Sealing cap

\* Per tarature inferiori a 70 Bar: Q = 12l/min \* For setting less than 70 Bar: Q = 12 l/min